

# Irrigation and Drainage Engineering

(Soil Water Regime Management)

(ENV-549, A.Y. 2025-26)

4ETCS, Master option

**Prof. Paolo Perona, Dr. Giulio Calvani**  
Platform of Hydraulic Constructions



Lecture 4.2. Gravity irrigation:  
Crossing infrastructures and  
control techniques: upstream  
vs downstream regulation

# Infrastructures (crossing ways)

# Crossing (infra)structures

**Long obstacles** (depressions, mounds, buttes, hills, etc.) :

- depressions
  - ✓ backfill
  - ✓ aqueduct
  - ✓ long siphon
- Buttes and hills
  - ✓ cut-and-cover section
  - ✓ tunnel

**Short obstacles** (road, river, etc.) :

- overpass: canal bridge
- underpass
  - ✓ at level: gutter or culvert<sup>1</sup>
  - ✓ by inverted siphon<sup>2</sup>

<sup>1</sup> when the water level in the canal is lower than the obstacle

<sup>2</sup> when the water level is at the same height as the obstacle



# Bridge-canal (overpass)

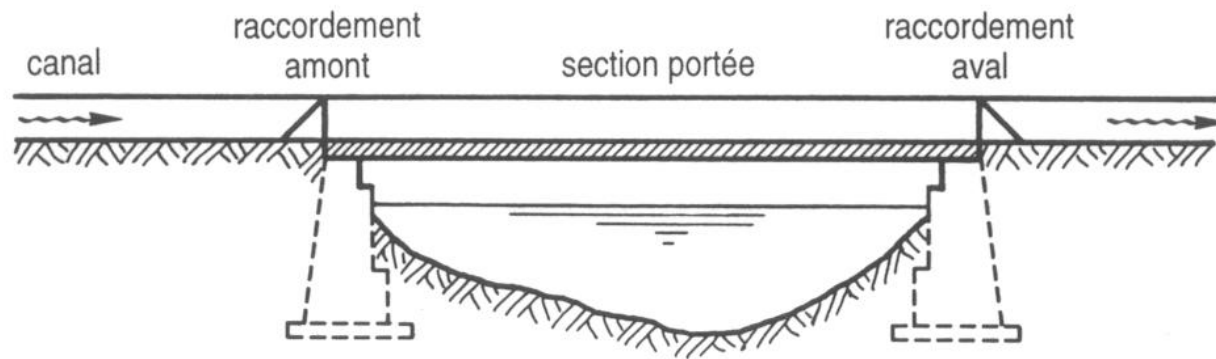

## Bridge - canal

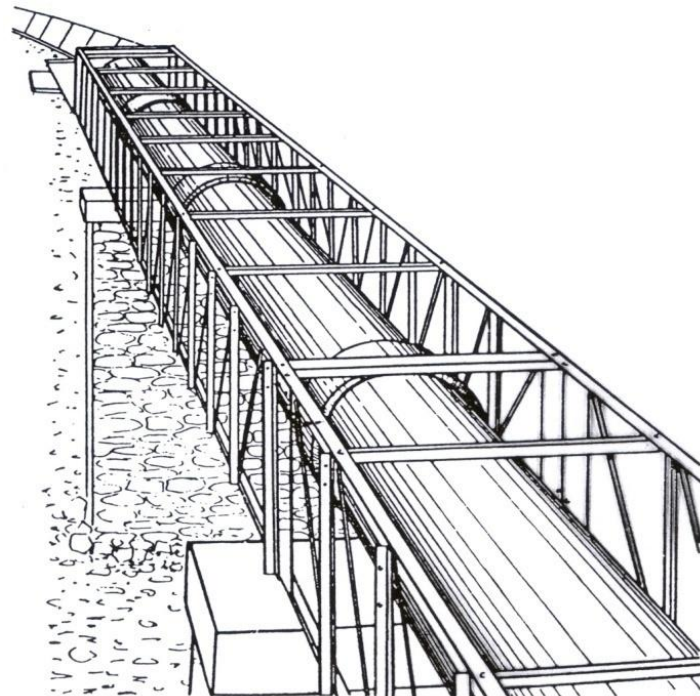

# Underpass – Gutter or culvert

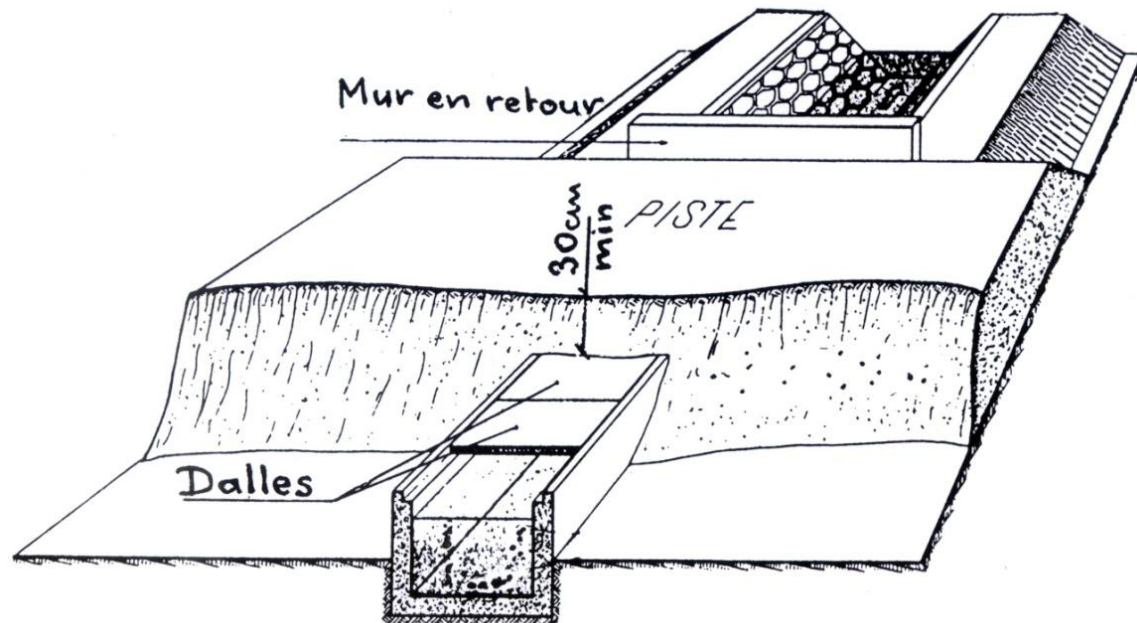

Usually designed based on open channel law  
(Manning-Strickler equation)

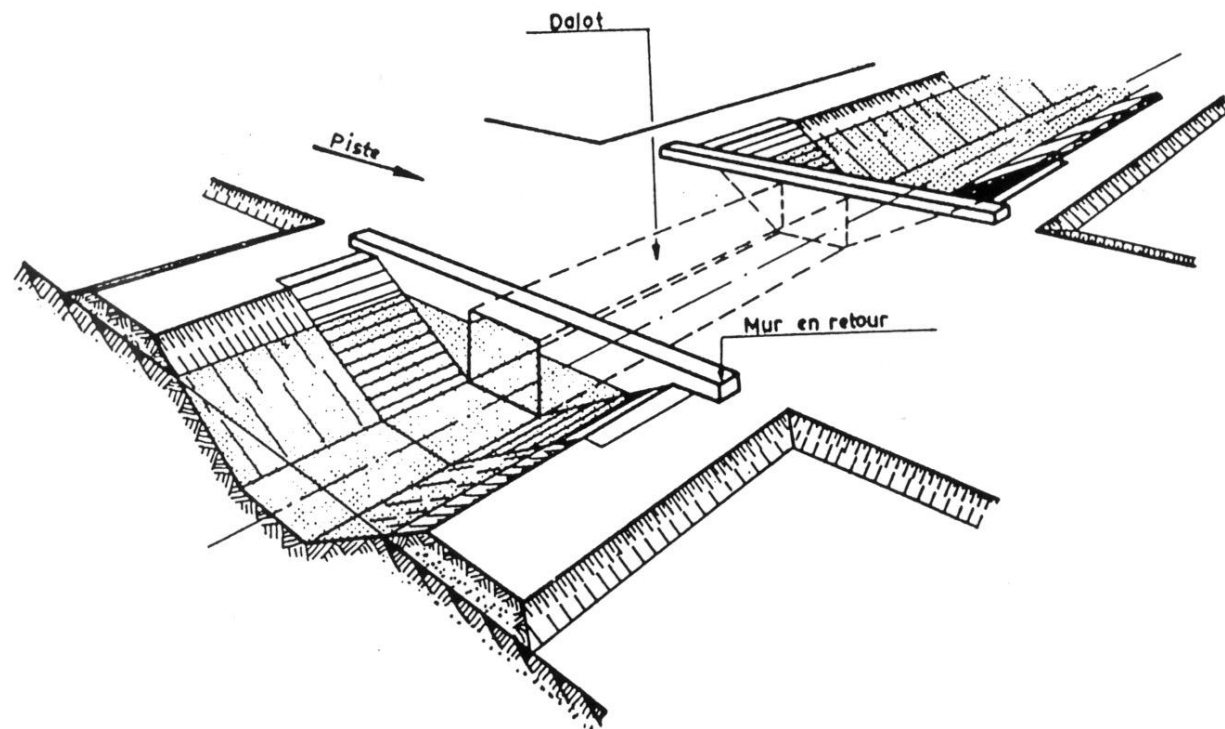

Energy losses due to contraction-expansion effects at the entrance and exit

# Underpass – Gutter or culvert

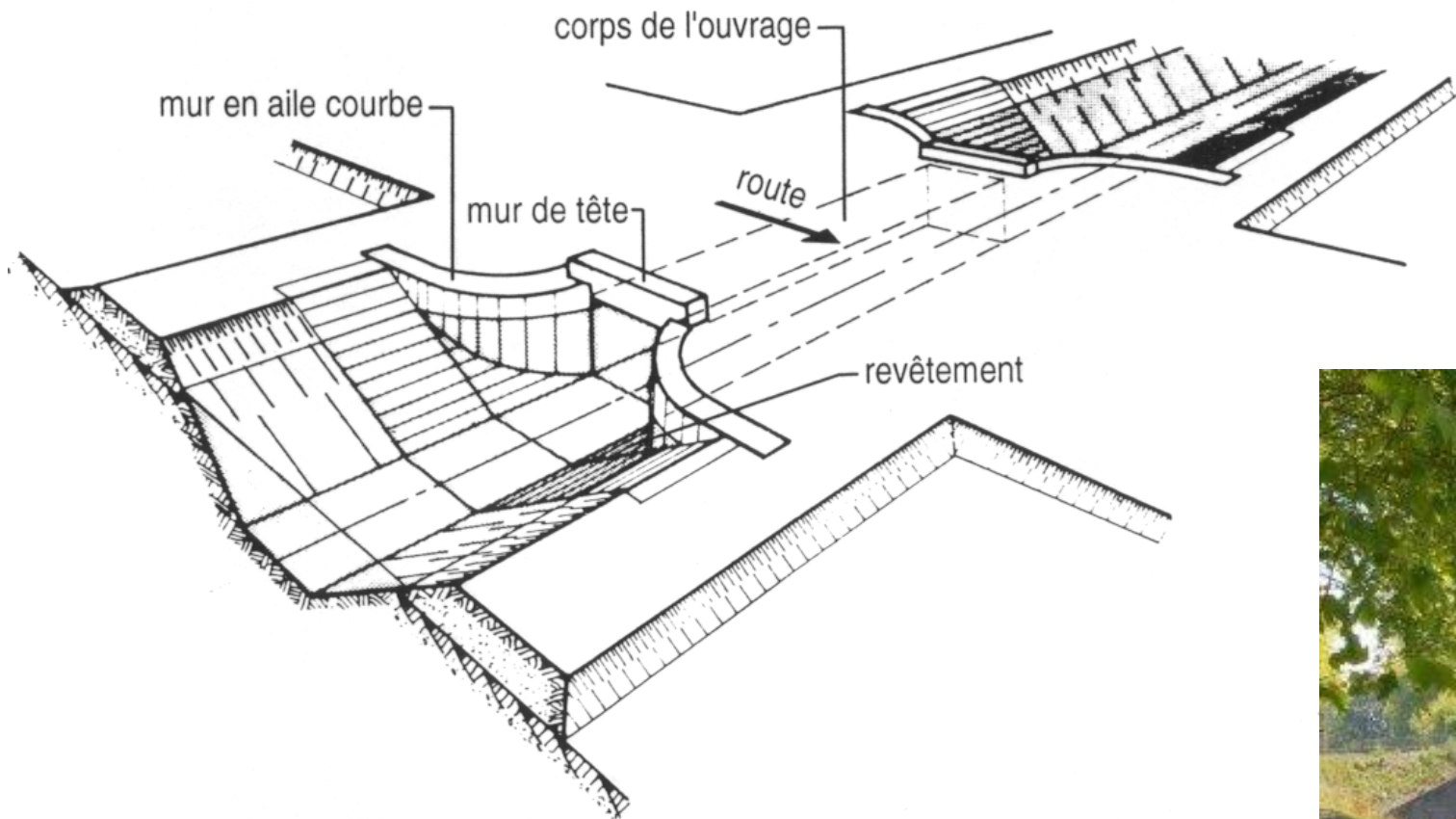

**Dalot with progressive connection**

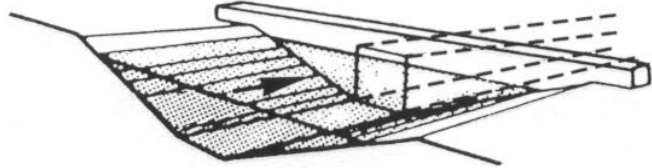
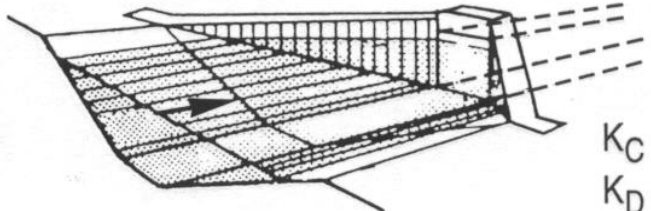
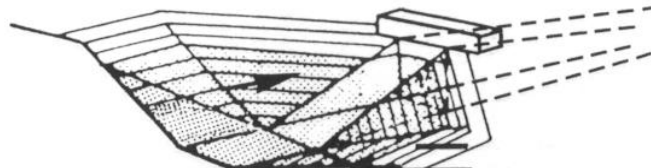
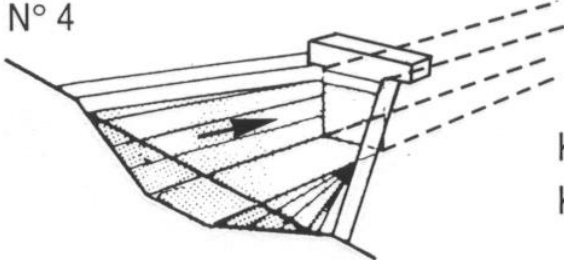
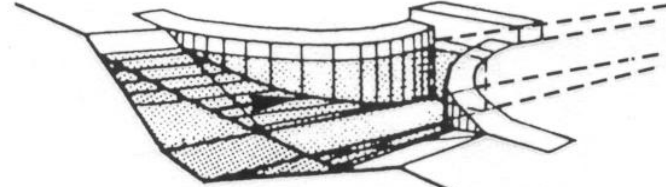

# Empirical coefficients for energy loss

RACCORDEMENT.	RACCORDEMENT
<p>BRUSQUE <math>K_C = 0.5</math> <math>K_D = 1.0</math></p> 	<p>N° 3 <math>K_C = 0.2</math> <math>K_D = 0.4</math></p> 
<p>N° 1 <math>K_C = 0.3</math> <math>K_D = 0.6</math></p> 	<p>N° 4 <math>K_C = 0.1</math> <math>K_D = 0.3</math></p> 
<p>N° 2 <math>K_C = 0.25</math> <math>K_D = 0.5</math></p> 	

**Standardised hydraulic connections**

# Underpass – Inverted siphon

Cross-section of an  
inverted siphon  
under the road

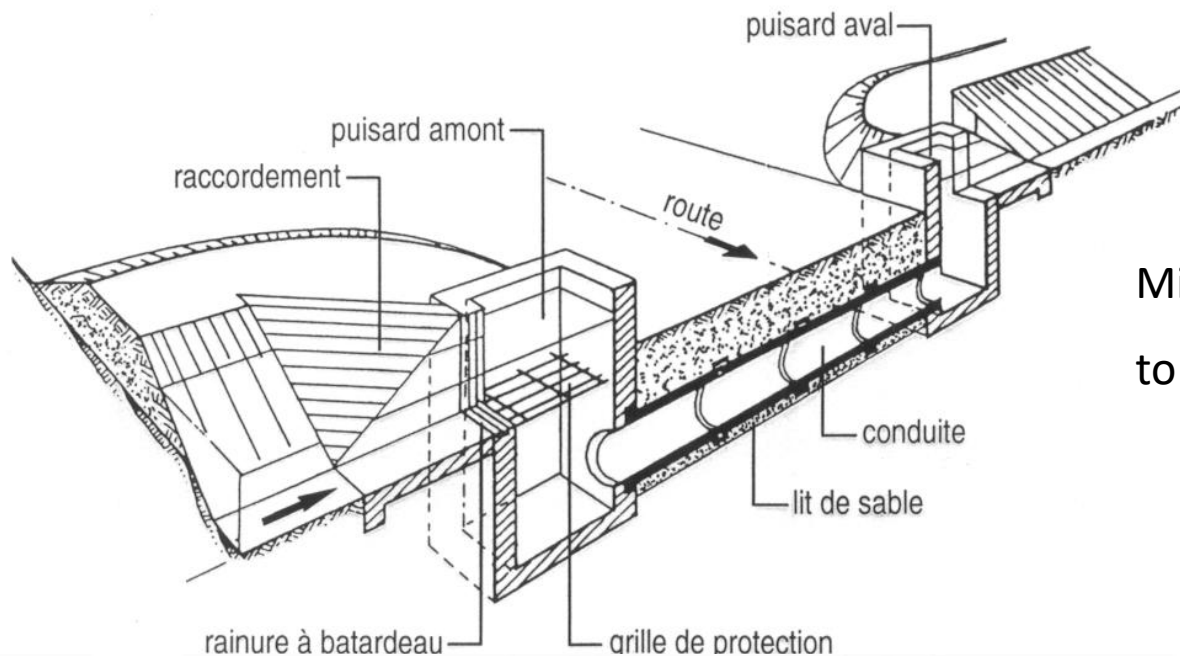

Minimum flow velocity (0.5 m/s)  
to avoid sedimentation

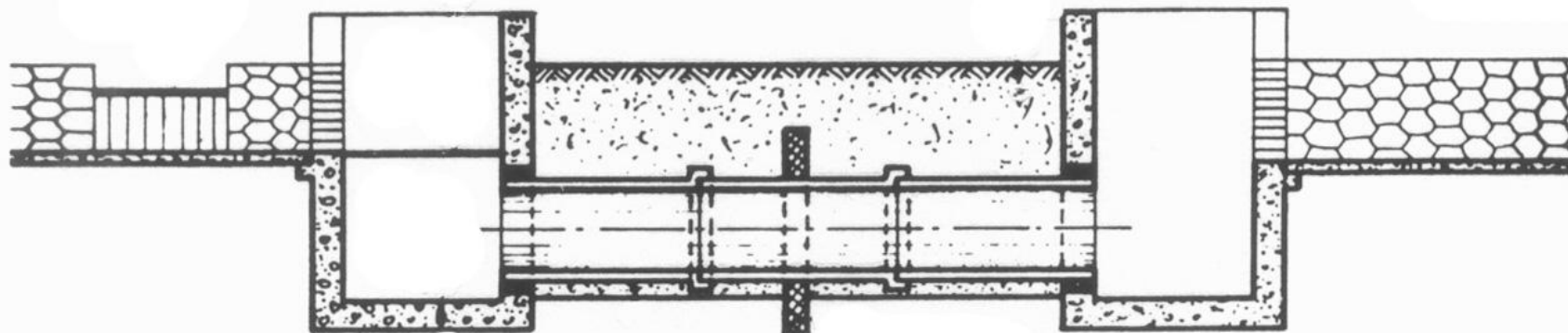

# Point structures for water level control

# Water level control

## Why do we need to monitor water levels and flows in canals

- proper operation of distribution structures
- reducing "dead zones"
- protection of canals
- protecting the perimeter against overflows



- ➔ For example: we need to maintain the water level between a minimum value (to protect canals and reduce dead zones) and a maximum value (for safety reasons)

# Hydraulic management of an irrigation network

## *Upstream regulation*

Flow rate injected into the network regulated at the upstream intake structure; constant, but adjusted from time to time according to changing needs

→ forced rotation irrigation

→ need to control the water level

- manual adjustment
- control by static structures
- automatic valve control

## *Downstream regulation*

Variable injection rate depending on demand

→ need to pass on variations in demand to the intake structure

- control by valves with constant downstream level
- control by cylindrical valves
- control by disc valves



**Transversal gates**



# Cross-section and plan view of a section of canal with upstream regulation

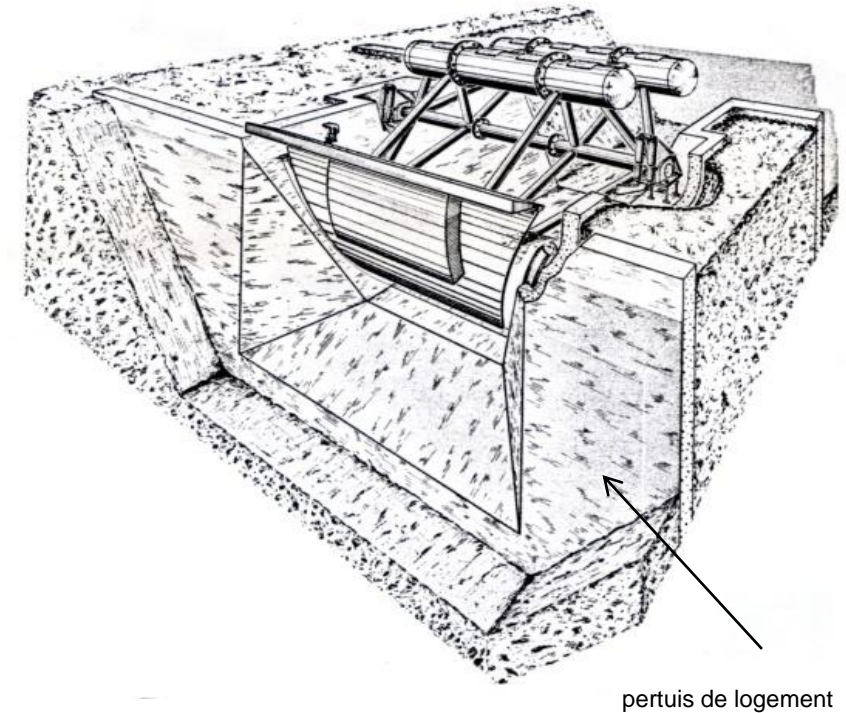
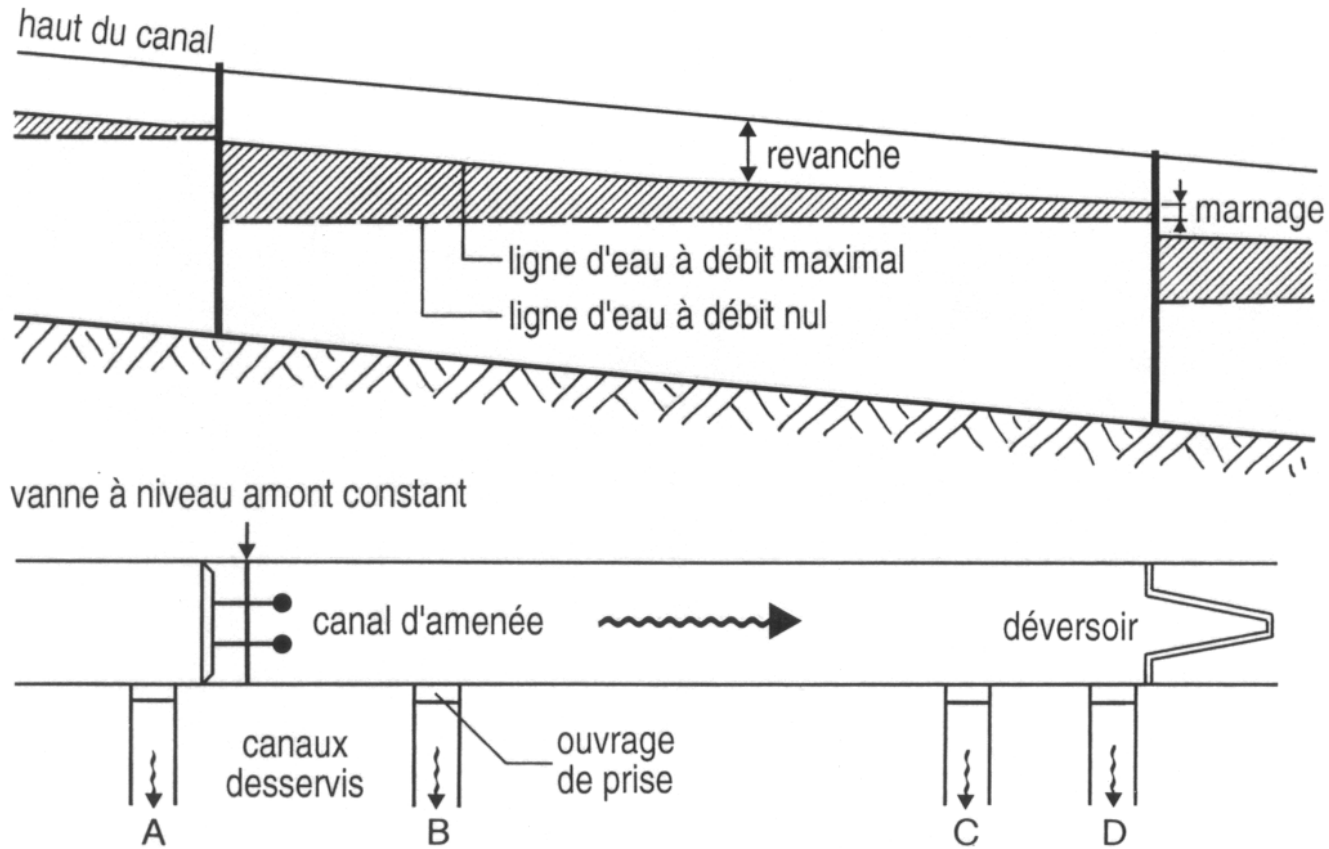

The position and density of the control structures depends on:

- channel slope
- position of bypass channels
- admissible tidal range
- imposed constraints

# Advantages and disadvantages of upstream regulation

## Advantages

- simplicity; possibility of regulation by means of simple, rustic and inexpensive structures (weirs)

## Disadvantages

- Impossible to irrigate on demand
- difficulties in estimating the flow rate to be introduced into the network (flow rate required + en-route losses)
- difficulties in coping with unexpected non-consumption of water<sup>1</sup>



We shall study the functioning of these structures in lecture 5

---

<sup>1</sup> following, for example, closure of the valves during a storm → loss of water stored in the tabs

## Plan and cross-section of a section of canal with downstream regulation

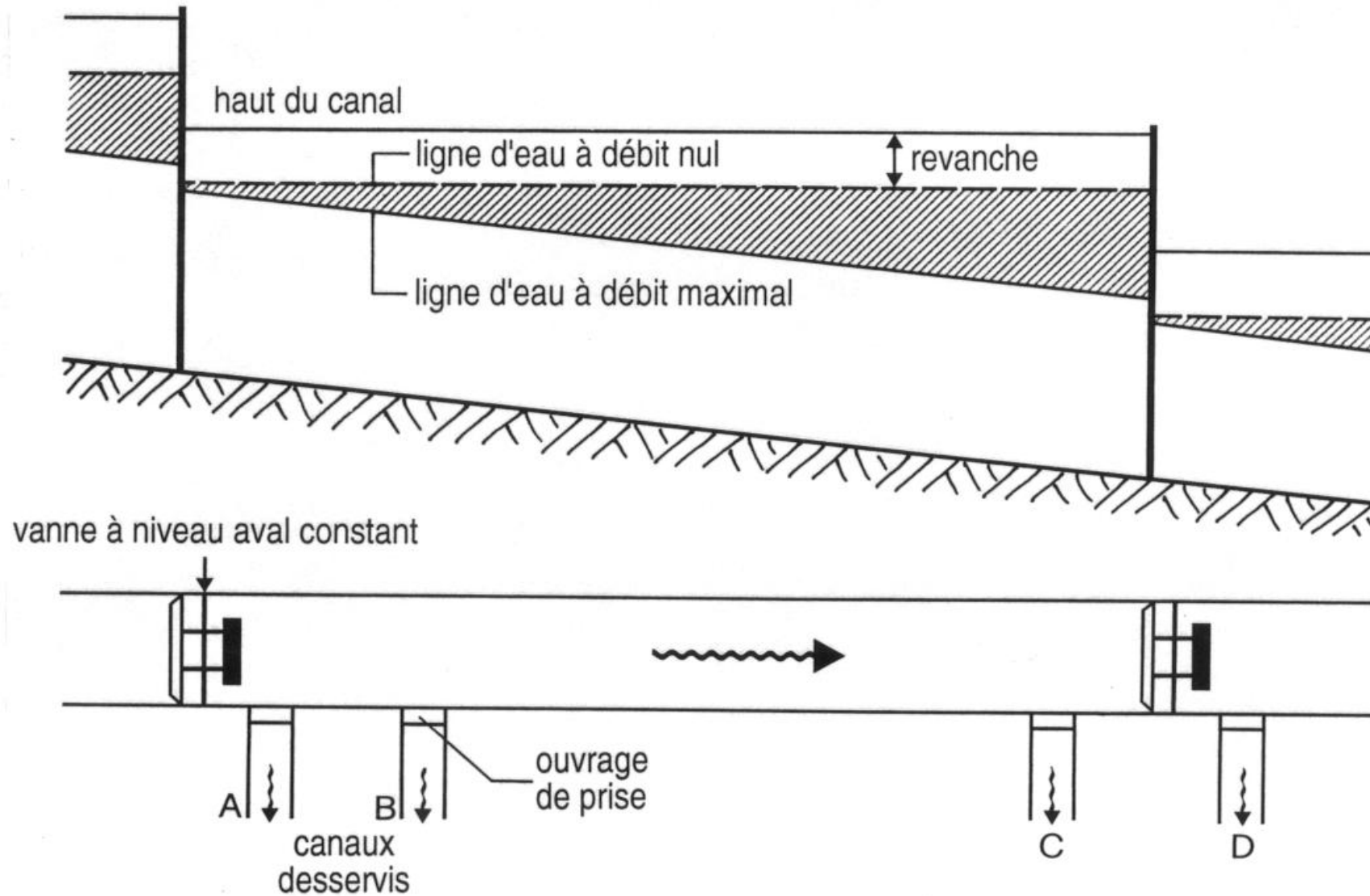

# Advantages and disadvantages of downstream regulation

## Advantages

- automatic flow regulation
- possibility of irrigating on demand

## Disadvantages

- position of the water line at zero flow: succession of horizontal planes
  - ➔ need to raise the banks (prohibitively expensive when the slope  $> 0.0003$ )
- high valve density
- difficulty in obtaining a stable regime in the canals



We shall study the functioning of this structure in lecture 5

# Upstream regulation using static structures (weirs)

## Hydraulic functioning of weirs

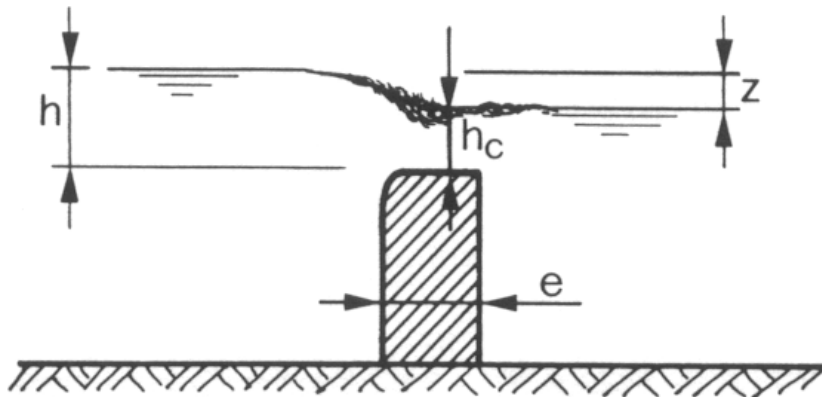

- $h \geq 2e$  thin wall (flow measurements)
  - $h < 2e$  thick wall
  - $z \geq 0.4h$  not flooded
  - $z < 0.4h$  flooded
- } flow + regulation

$$Q = m m_1 \sqrt{2g} l h^{3/2}$$

Q: flow over the weir

m: flow coefficient depending on the thickness of the weir and its shape (approx. 0.4)

m1: coefficient depending on the orientation of the weir in relation to the flow

l: length of spillway

h: load on the weir

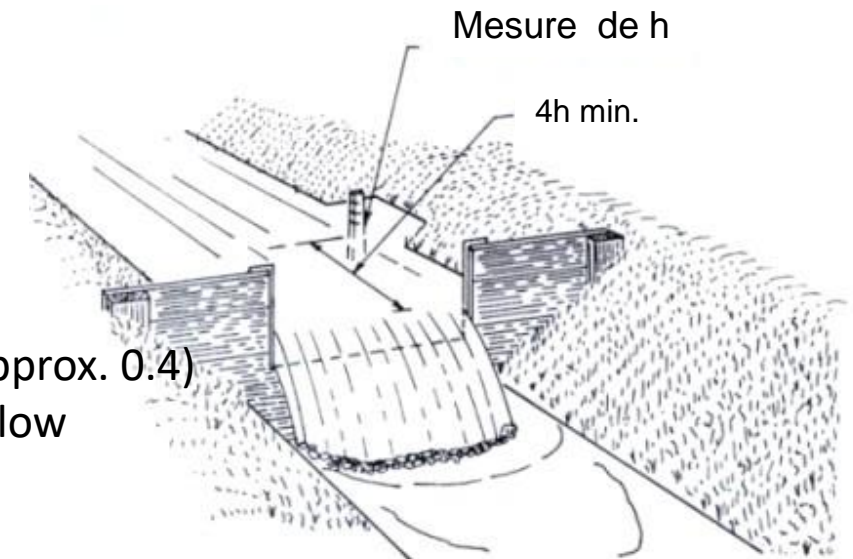

# Thin-wall weirs for flow measurement

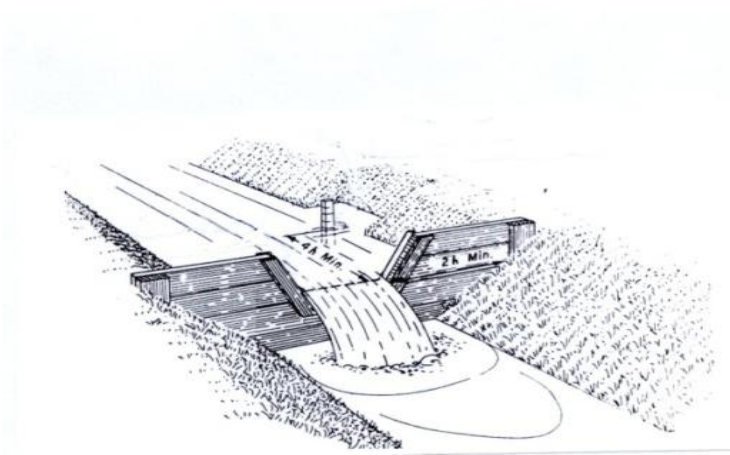
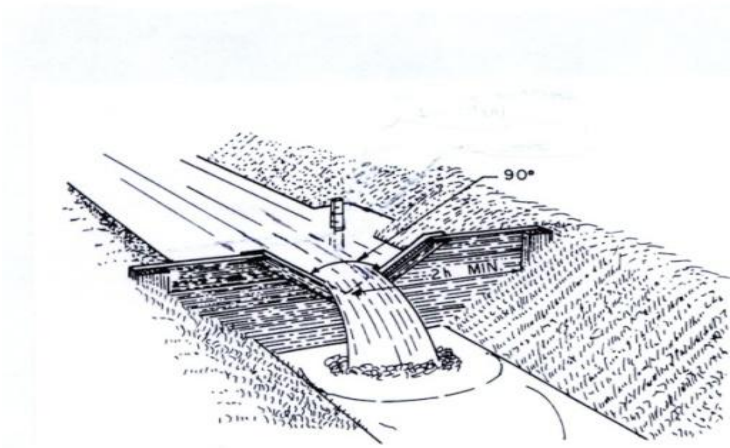
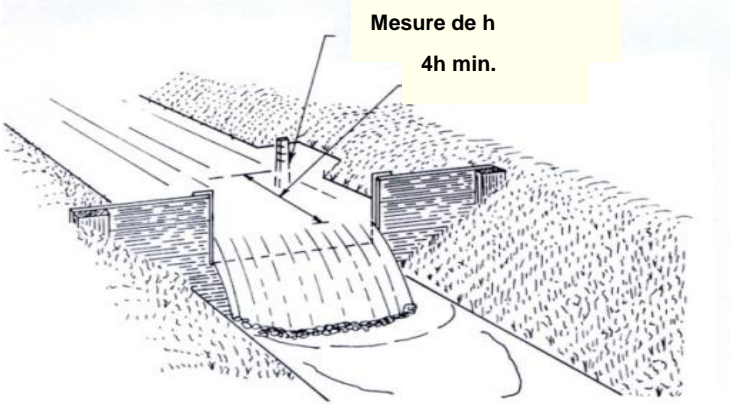

## Level control using thick wall weirs

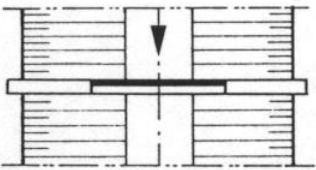
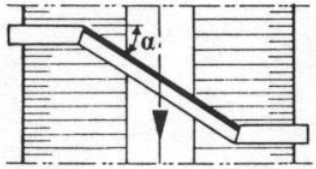
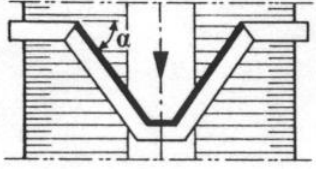
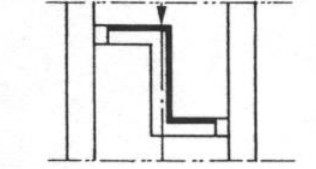
Forme du déversoir	Coefficient $m_1$	Formule pour calculer le débit
	Transversal $m_1 = 1.00$	$Q = 0.40 l \sqrt{2g} h^{3/2}$
	Oblique pour $\alpha < 45^\circ$ $m_1 = 0.95$	$Q = 0.38 l \sqrt{2g} h^{3/2}$
	Type Giraudet pour $45^\circ < \alpha < 70^\circ$ $m_1 = 0.90$	$Q = 0.36 l \sqrt{2g} h^{3/2}$
	Longitudinal $m_1 = 0.85$	$Q = 0.34 l \sqrt{2g} h^{3/2}$





Piano-Key Weir type



Regulation weirs

